





Anschlußart	Typ	Anzugsdrehmoment	Klemmbereich Kabel	Schienen- bzw. Flachbandabmessungen
Terminal type	Type	Tightening torque	Clamping range	Size flat strip
 Flachanschluß M8	F-M8x16	12 - 15 Nm	Kabelschuhe nach DIN 46234 u. 46235	-
Screw terminal M8	F-M8x16	12 - 15 Nm	cable lugs acc. to DIN 46234 and 46235	-
 Schellenklemmenanschluß	S00	2,6 Nm	1,5 - 70 mm ² Cu	Stromschiene max. 9x8 Flex. Flachband max. 6x9x0,8
Clip terminal	S00	2,6 Nm	1,5 - 70 mm ² Cu	Busbars max. 9x8 flexible flat strip max. 6x9x0,8
 Prismenklemmenanschluß	P0070	2,6 Nm	10 - 70 mm ² Al/Cu	-
Prism clamp	P0070	2,6 Nm	10 - 70 mm ² Al/Cu	-
 Fahrstuhlklemme	F57	2,6 Nm	1,5 - 70 mm ² Cu	-
Elevator terminal	F57	2,6 Nm	1,5 - 70 mm ² Cu	-

 max. 20mm

Gebrauchsanleitung Installation Instructions

GA-T015

1399001b

CE NH-Sicherungslasttrennschalter
Gr. 00 für 1-polige
Sammelschienensysteme
LV HRC fuse switch disconnecter
Size 00 for single pole
busbar systems

 Vor Beginn der Arbeiten Gerät spannungsfrei schalten. Inbetriebsetzung und Wartung nur durch Fachpersonal. To prevent electrical shock disconnect from power source before installing or servicing. Work and maintenance by skilled staff only.

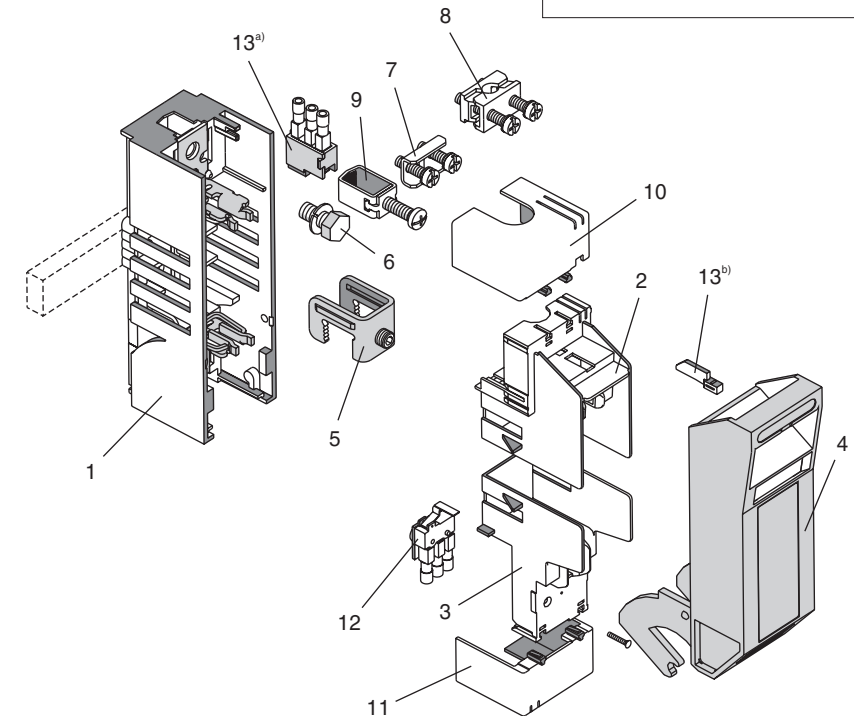

- | | | | |
|---|------------|----|--------------------------|
| 1 | U-LTL00-1 | 8 | P0070 |
| 2 | BO-LTL00-1 | 9 | F57 |
| 3 | BU-LTL00-1 | 10 | GO-LTL00-1 |
| 4 | D-LTL00-1 | 11 | GU-LTL00-1 |
| 5 | SK00/10 | 12 | K-LTL00-1/H |
| 6 | F-M8x16 | 13 | eV-LTL00 ^{a)b)} |
| 7 | S00 | | |

